

# CSO V2 2014 SETTING SHEET Ver.1.0

Super-V2 Flexible Chassis

COMMENTS:

**Team CSO R/C Racing Product**

Date: 04/10/2015

Driver: TURBOLELE87

EVENT: TROFEO MARKA RACING CASTELNUOVO SCRIVIA

Track/Tation: CASTELNUOVO SCRIVIA - CHILELLI TRACK

**FRONT**

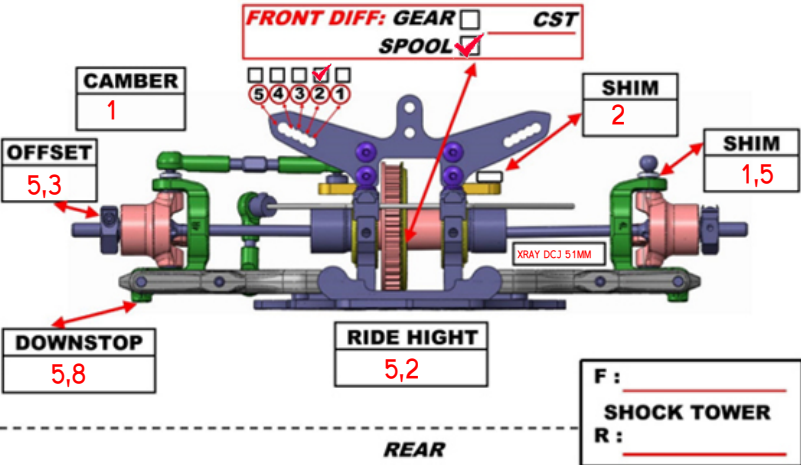

**REAR**

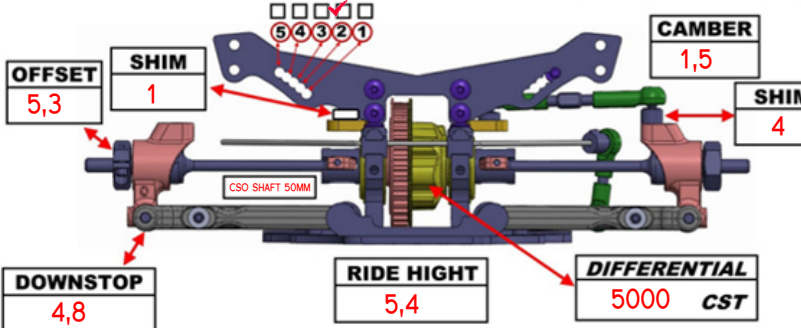

Track Info:  Indoor  Outdoor  CARPET  ASPHALT

Temp: Track 22 / Weather 20

Track Type:  Technical /  Mixed /  Fast

Track Traction:  Low /  Medium /  High

BODY: PROTOFORM LTCR

WING: MR33 HARD

MOTOR: TEAM POWERS PLUTONIUM V2

ESC: LRP FLOW WORKS TEAM NO TIMING

BATTERY: MARKA 6000

TIRES: F LRP 32 / R LRP 32

DIAMETER: F / R

INSERS: F / R

ADDITIVE: F LRP CARPET 3 / R LRP CARPET 3

ADDITIVE TIME (MINS.): 15

**FRONT REAR**

OIL	350	350
SPRING	XRAY PROG. 2.5-2.8	XRAY 2.6N
HOLES DIAMETER	4 - 1,1MM	4 - 1,1MM
PRELOAD	OMM	OMM
FOAM INSERTS		
REBOUN	0%	0%
LENGTH	OMM	OMM
O-RING ON SHAT		

SUSPENSION BLOCK (A)	SUSPENSION BLOCK (B)	CHASSIS	SUSPENSION BLOCK (C)	SUSPENSION BLOCK (D)
	2,5 DEG.	CSO V2 2014	2,5 DEG.	2,5 DEG.
ROLLING CENTER SHIM	ROLLING CENTER SHIM	TOP DESK	ROLLING CENTER SHIM	ROLLING CENTER SHIM
		CSO V2 2014 1.7MM		

