

COMMENTS:

ECS 44mm (Front) CSO-20195

Tyre warming time: 10 min

Best Lap: 13.840

Final Position:

Date: April 5, 2014

Driver: Andrea Gavi

EVENT: Test

Track/Tation: RC Model Imperia - Imperia - IT

FRONT

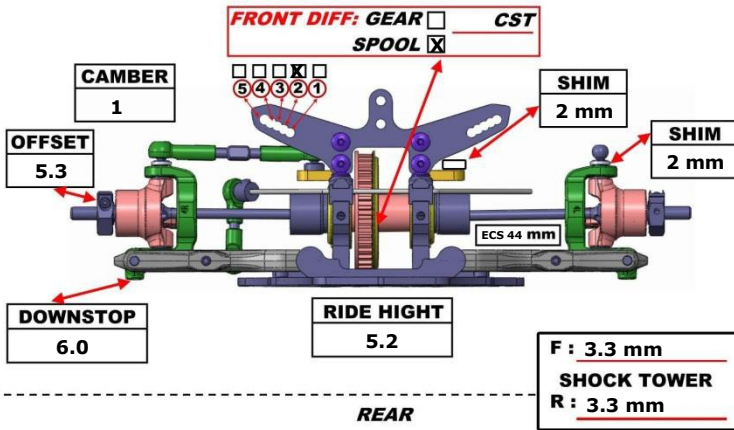

REAR

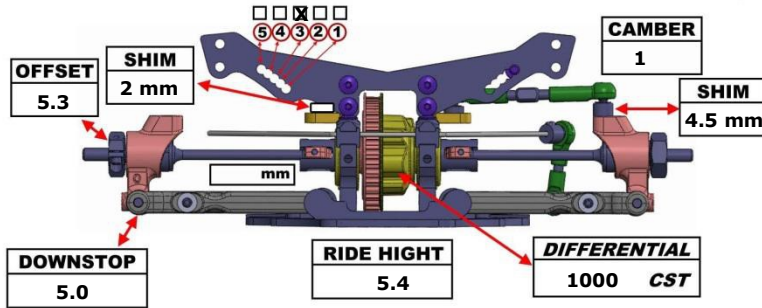

Track Info: Indoor Outdoor CARPET ASPHALT

Temp: Track 35° / Weather Sun 24°

Track Type: Technical / Mixed / Fast

Track Traction: Low / Medium / High

BODY : LTRC WING:

MOTOR : LRP 13.5 TIMING: No timing

ESC : Hobbywing V3 BATTERY: Nanotech

TIRES : F LRP G 32 / R LRP G 32

DIAMETER: F / R

INSERS : F / R

ADDITIVE : F Team Powers / R Team Powers

TRACK COMMENTS:

Track treated with sugar and cola

FRONT REAR

OIL	400	400
SPRING	1.4	1.4
HOLES DIAMETER	1.1 - 4 holes	1.1 - 4 holes
PRELOAD		
FOAM INSERTS	No	No
REBOUN	0 %	0 %
LENGTH		
O-RING ON SHAT		

SUSPENSION BLOCK (A)	SUSPENSION BLOCK (B)	CHASSIS	SUSPENSION BLOCK (C)	SUSPENSION BLOCK (D)
0	2.5	V2 Flex	2.5	3
ROLLING CENTER SHIM	ROLLING CENTER SHIM	TOP DESK	ROLLING CENTER SHIM	ROLLING CENTER SHIM
No	No	2 mm	No	No

