

COMMENTS:

Mounted Front spool axle
CSO-18053SH, ECS
44mm (Front) CSO-20195

Position 4° Place
Category Stock 13.5T

Date: May 11, 2014

Driver: Davide Gianuzzi

EVENT: Trofeo LRP HRC Hermes

Track/Tation: Bovisio Masciago - Italy

FRONT

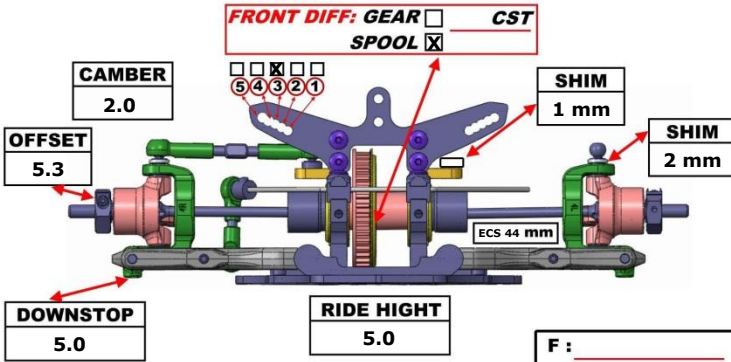

REAR

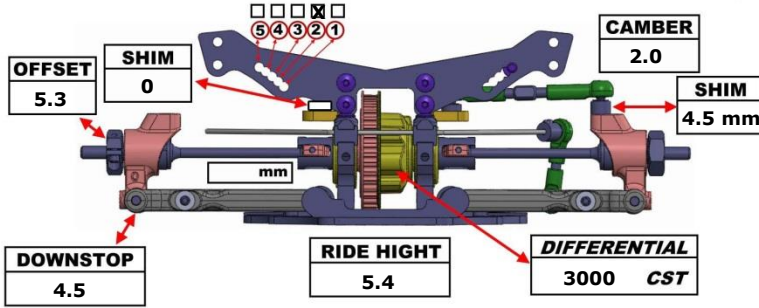

Track Info: Indoor Outdoor CARPET ASPHALT

Temp: Track 23° / Weather Sun/Cloudy

Track Type: Technical / Mixed / Fast

Track Traction: Low / Medium / High

BODY: Nardò WING: Bittydesign Hard

MOTOR: LRP 13.5 TIMING: No Timing

ESC: LRP BATTERY: R1 Wurks 7200 90C

TIRES: F LRP GE32 / R LRP GE32

DIAMETER: F / R

INSERTS: F / R

ADDITIVE: F Team Powers / R Team Powers

TRACK COMMENTS:

FRONT REAR

OIL	400	400
SPRING	RSD Gold	CSO 2.7
HOLES DIAMETER	1.1	1.1
PRELOAD		
FOAM INSERTS	No	No
REBOUN	0 %	0 %
LENGTH		
O-RING ON SHAT		

SUSPENSION BLOCK (A)	SUSPENSION BLOCK (B)	CHASSIS	SUSPENSION BLOCK (C)	SUSPENSION BLOCK (D)
0	2.5	CSO V3	2.5	2.5
ROLLING CENTER SHIM	ROLLING CENTER SHIM	TOP DESK	ROLLING CENTER SHIM	ROLLING CENTER SHIM
No	No	2 mm Standard	No	No

