

COMMENTS:

Mounted Front spool axle
CSO-18053SH, ECS
44mm (Front) CSO-20195

Position 2° Place
Category Stock 13.5T

Date: March 30, 2014

Driver: Davide Gianuzzi

EVENT: 1° Social Race La Valletta

Track/Tation: La Valletta Varese - Italy

FRONT

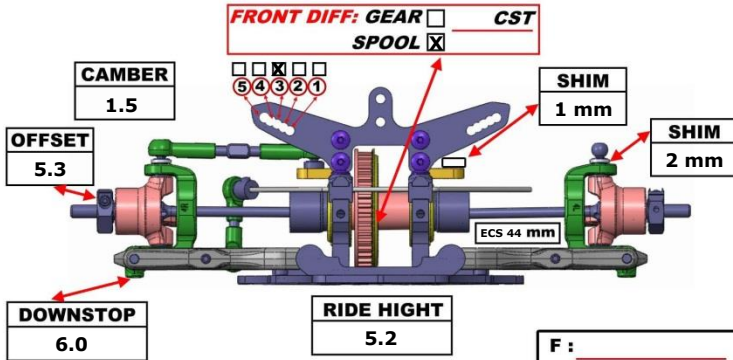

REAR

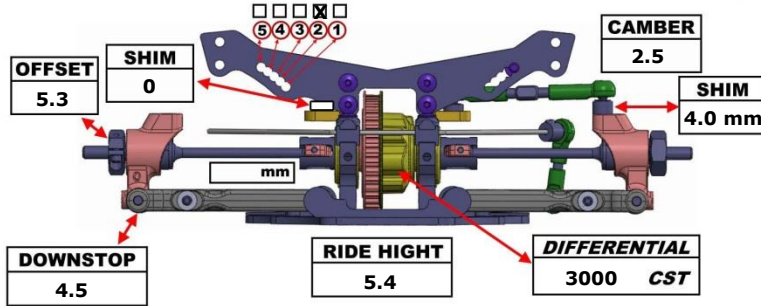

Track Info: Indoor Outdoor CARPET ASPHALT

Temp: Track 18° / Weather Sun

Track Type: Technical / Mixed / Fast

Track Traction: Low / Medium / High

BODY: Nardò WING: Bittydesign Hard

MOTOR: SP 13.5 TIMING: No Timing

ESC: Cirtix BATTERY: LRP 6000

TIRES: F Ride 34 / R Ride 34

DIAMETER: F / R

INSERS: F / R

ADDITIVE: F Team Powers / R Team Powers

TRACK COMMENTS:

Track with medium grip and with elevation changes



	FRONT	REAR
OIL	400	450
SPRING	RSD Silver	CSO 2.7
HOLES DIAMETER	1.1c	1.1
PRELOAD		
FOAM INSERTS	Yes	Yes
REBOUN	0 %	0 %
LENGTH		
O-RING ON SHAT		

SUSPENSION BLOCK (A)	SUSPENSION BLOCK (B)	CHASSIS	SUSPENSION BLOCK (C)	SUSPENSION BLOCK (D)
0	2.5	CSO V3	2.5	3.0
ROLLING CENTER SHIM	ROLLING CENTER SHIM	TOP DESK	ROLLING CENTER SHIM	ROLLING CENTER SHIM
No	No	2 mm Standard	No	No

