

# 2014 CSO V2 SETTING SHEET Ver.1.0

Super-V2 Flexible Chassis

## COMMENTS:

Feel Easy to drive  
Maybe too soft springs  
Good traction feeling

Position 1° Place  
Category Modified

## Team CSO R/C Racing Product

Date: March 09, 2014

Driver: Gonzalo Gonzo Garcia

EVENT: 1° Prueba Nacional Federaciones 2014

Track/Tation: Capa Madrid - Spain

### FRONT

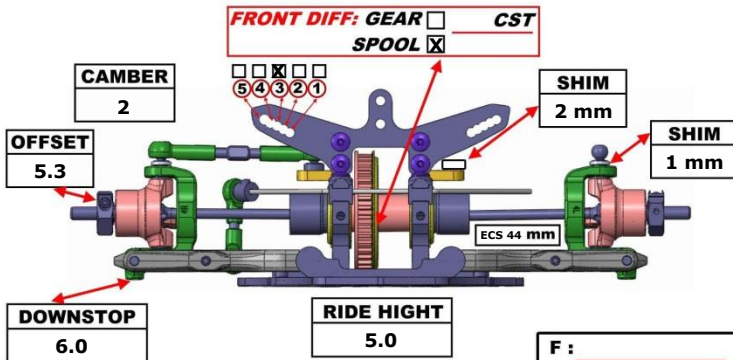

### REAR

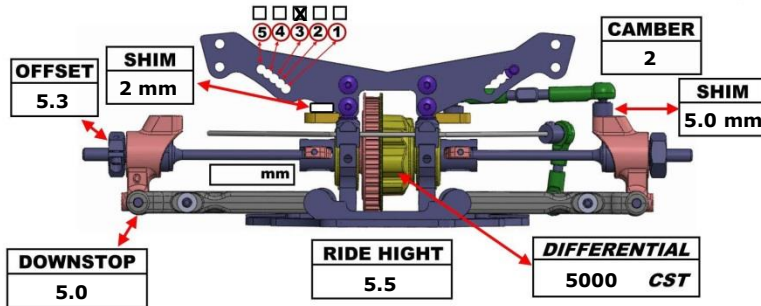

Track Info:  Indoor  Outdoor  CARPET  ASPHALT

Temp: Track \_\_\_\_\_ / Weather \_\_\_\_\_

Track Type:  Technical /  Mixed /  Fast

Track Traction:  Low /  Medium /  High

BODY : XFR WING: Standard

MOTOR : Team Orion 4.0 TIMING: 1MM

ESC : Vortex R10Pro BATTERY: 7200 Much More

TIRES : F Ride 32 / R Ride 32

DIAMETER: F / R

INSERTS : F / R

ADDITIVE : F MR33 / R MR33

TRACK COMMENTS:

### FRONT REAR

<b>OIL</b>	350	350
<b>SPRING</b>	CSO 2.6	CSO 2.6
<b>HOLES DIAMETER</b>	1.1	1.1
<b>PRELOAD</b>		
<b>FOAM INSERTS</b>		
<b>REBOUN</b>	0 %	0 %
<b>LENGTH</b>		
<b>O-RING ON SHAT</b>		



<b>SUSPENSION BLOCK (A)</b>	<b>SUSPENSION BLOCK (B)</b>	<b>CHASSIS</b>	<b>SUSPENSION BLOCK (C)</b>	<b>SUSPENSION BLOCK (D)</b>
0	2.5	V2 Flex	2.5	3.0
<b>ROLLING CENTER SHIM</b>	<b>ROLLING CENTER SHIM</b>	<b>TOP DESK</b>	<b>ROLLING CENTER SHIM</b>	<b>ROLLING CENTER SHIM</b>
No	No	2 mm Standard	No	No

