

COMMENTS:

Front spool axle
 CSO-18053H, Membranes
 Hard CSO-18077H, ECS
 44mm (Front) CSO-20195,
 Rear D 2.5 Degree Toe-in
 CSO-V22028BD

Date: December 8, 2013

Driver: Luca Giovannoni

EVENT: Charity Race 13.5 Stock

Track/Tation: Scandiano - Italy

FRONT

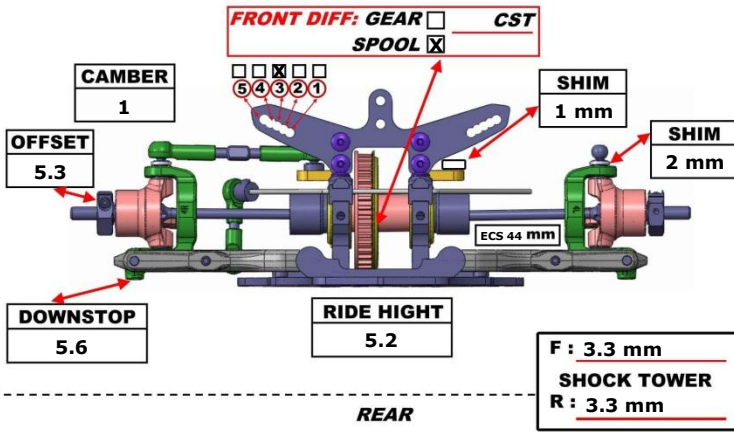

REAR

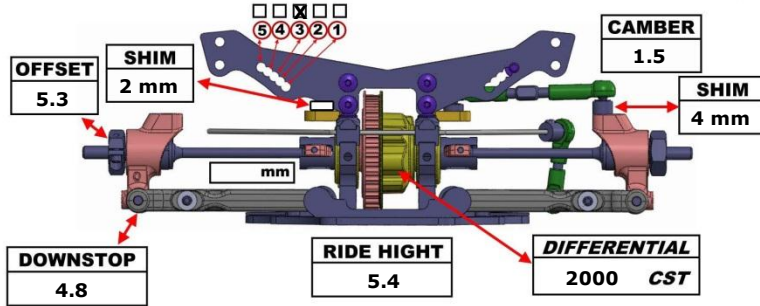

Track Info: Indoor Outdoor CARPET ASPHALT

Temp: Track 15° / Weather Cloudy/Sunny

Track Type: Technical / Mixed / Fast

Track Traction: Low / Medium / High

BODY: Nardò WING: _____

MOTOR: 13.5T Reedy TIMING: Blinky

ESC: Orca BATTERY: nVision 6400

TIRES: F Ride 30 / R Ride 30

DIAMETER: F / R

INSERS: F / R

ADDITIVE: F Hudy / R Hudy

TRACK COMMENTS:



	FRONT	REAR
OIL	400	400
SPRING	CSO 2.5	CSO 2.7
HOLES DIAMETER	1.2	1.2
PRELOAD		
FOAM INSERTS		
REBOUN	0	0
LENGTH	56.5 mm	56.5 mm
O-RING ON SHAT		

SUSPENSION BLOCK (A)	SUSPENSION BLOCK (B)	CHASSIS	SUSPENSION BLOCK (C)	SUSPENSION BLOCK (D)
0	2.5	Flex	2.5	2.5
ROLLING CENTER SHIM	ROLLING CENTER SHIM	TOP DESK	ROLLING CENTER SHIM	ROLLING CENTER SHIM
No	No	2 mm	No	No

