

COMMENTS:

Mounted CSO-V22005C hard Chassy, Front spool axle CSO-18053H, Membranes Hard CSO-18077H, ECS 44mm (Front) CSO-20195, Rear D 2.5 Degree Toe-in CSO-V22028BD, Fan R1 Wurks

Date: February 16, 2014

Driver: Paolo Massari

EVENT: Automodelli Race 13.5 Stock

Track/Tation: Angiolino Remedello - Italy

FRONT

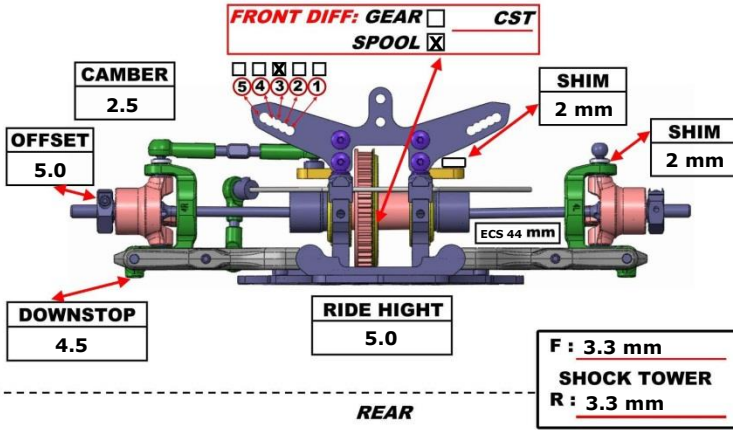

REAR

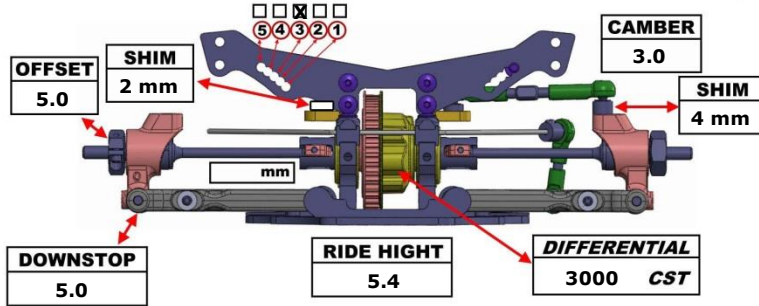

Track Info: Indoor Outdoor CARPET ASPHALT

Temp: Track 15° / Weather Cloudy/Sunny

Track Type: Technical / Mixed / Fast

Track Traction: Low / Medium / High

BODY: Nardò Bitty WING: M33

MOTOR: 13.5T Team Power TIMING: No

ESC: Radon Team Power BATTERY: 7200 R1 Wurks

TIRES: F G32 LRP / R G32 LRP

DIAMETER: F / R

INSERS: F / R

ADDITIVE: F WRC / R WRC

TRACK COMMENTS:

	FRONT	REAR
OIL	450	400
SPRING	RSD Gold	RSD Silver
HOLES DIAMETER	1.1	1.1
PRELOAD		
FOAM INSERTS		
REBOUN	0	0
LENGTH	4.2	4.2
O-RING ON SHAT		

SUSPENSION BLOCK (A)	SUSPENSION BLOCK (B)	CHASSIS	SUSPENSION BLOCK (C)	SUSPENSION BLOCK (D)
0	2.5	Hard	2.5	2.5
ROLLING CENTER SHIM	ROLLING CENTER SHIM	TOP DESK	ROLLING CENTER SHIM	ROLLING CENTER SHIM
No	No	2 mm	No	No

