

**COMMENTS:**

CSO-18053SH, ECS  
44mm (Front) CSO-20195

Position 3° Place  
Category Stock 13.5T  
Best Lap Track 17.248

Date: May 25, 2014

Driver: Sergio Pignataro

EVENT: Trofeo Social La Valletta

Track/Tation: Varese - Italy

**FRONT**

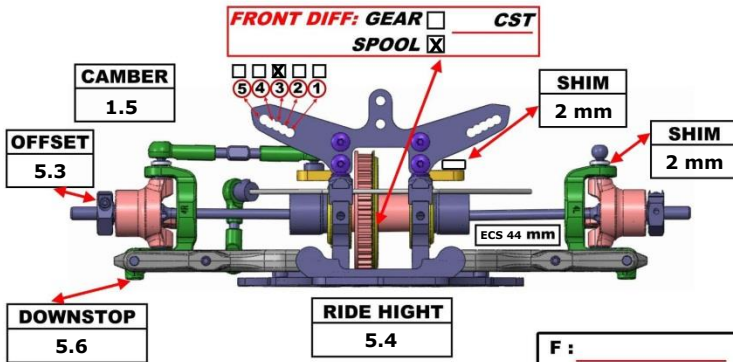

**REAR**

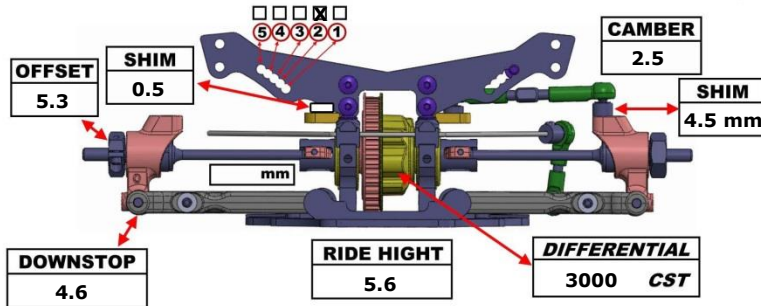

Track Info:  Indoor  Outdoor  CARPET  ASPHALT

Temp: Track 40° / Weather Sun/Cloudy

Track Type:  Technical /  Mixed /  Fast

Track Traction:  Low /  Medium /  High

BODY : Nardò WING: Bittydesign Hard

MOTOR : SP V3 13.5 TIMING: No Timing

ESC : Reventon Stock BATTERY: nVision 6400 90C

TIRES : F Ride Rex 34 / R Ride Rex 34

DIAMETER: F / R

INSERTS : F / R

ADDITIVE : F Team Powers / R Team Powers

TRACK COMMENTS:

**FRONT REAR**

<b>OIL</b>	400	450
<b>SPRING</b>	RSD Silver	RSD Blue
<b>HOLES DIAMETER</b>	1.1 4x	1.1 4x
<b>PRELOAD</b>		
<b>FOAM INSERTS</b>	Si	Si
<b>REBOUN</b>	25 %	25 %
<b>LENGTH</b>		
<b>O-RING ON SHAT</b>		



<b>SUSPENSION BLOCK (A)</b>	<b>SUSPENSION BLOCK (B)</b>	<b>CHASSIS</b>	<b>SUSPENSION BLOCK (C)</b>	<b>SUSPENSION BLOCK (D)</b>
1°	2.5	CSO V3 Open	2.5	2.5
<b>ROLLING CENTER SHIM</b>	<b>ROLLING CENTER SHIM</b>	<b>TOP DESK</b>	<b>ROLLING CENTER SHIM</b>	<b>ROLLING CENTER SHIM</b>
No	No	2 mm Standard	No	No

