

COMMENTS:

Front spool axle
CSO-18053H, ECS
44mm (Front) CSO-20195,
Rear D 2.5 Degree Toe-in
CSO-V22028BD

Date: January 11, 2013

Driver: Valter Cola

EVENT: Test 13.5 Stock

Track/Tation: Roma T5 - Italy

FRONT

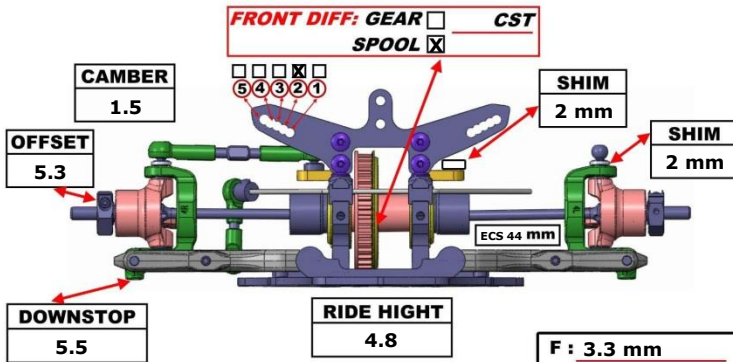

REAR

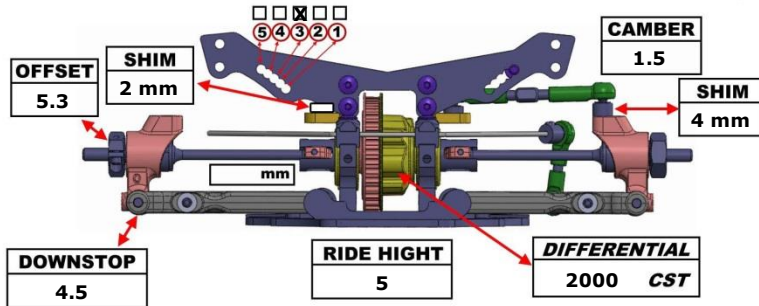

Track Info: Indoor Outdoor CARPET ASPHALT

Temp: Track 10° / Weather Cloudy

Track Type: Technical / Mixed / Fast

Track Traction: Low / Medium / High

BODY: LTCR WING:

MOTOR: 13.5 LRP TIMING: Blinky

ESC: Flow LRP BATTERY: GM 6800

TIRES: F LRP G32 / R LRP G32

DIAMETER: F / R

INSERTS: F / R

ADDITIVE: F MG-V3-Yellow / R MG-V3-Yellow

TRACK COMMENTS:



	FRONT	REAR
OIL	350	350
SPRING	RSD Silver	RSD Silver
HOLES DIAMETER	1.1	1.1
PRELOAD		
FOAM INSERTS		
REBOUN	25%	25%
LENGTH		
O-RING ON SHAT		

SUSPENSION BLOCK (A)	SUSPENSION BLOCK (B)	CHASSIS	SUSPENSION BLOCK (C)	SUSPENSION BLOCK (D)
0	2.5	V2 Flex	2.5	2.5
ROLLING CENTER SHIM	ROLLING CENTER SHIM	TOP DESK	ROLLING CENTER SHIM	ROLLING CENTER SHIM
No	No	2 mm	0 mm	0 mm

