

# 2014 CSO V2 SETTING SHEET Ver.1.0

Super-V2 Flexible Chassis

## COMMENTS:

Front spool axle  
CSO-18053H, ECS  
44mm (Front) CSO-20195,  
Rear D 2.5 Degree Toe-in  
CSO-V22028BD

Position 1° Place

## Team CSO R/C Racing Product

Date: March 16, 2014

Driver: Valter Cola

EVENT: Race Csen 13.5 Stock

Track/Tation: Roma T5 - Italy

### FRONT

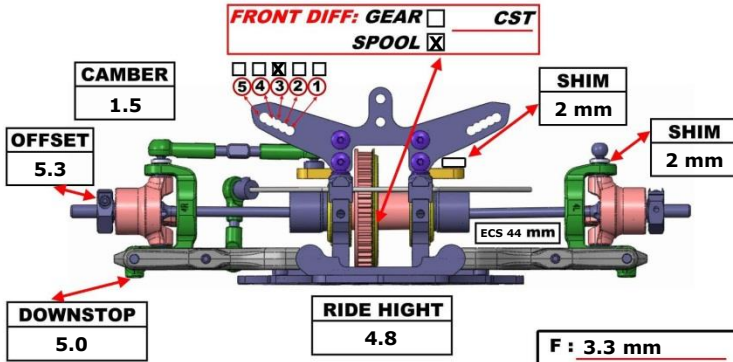

### REAR

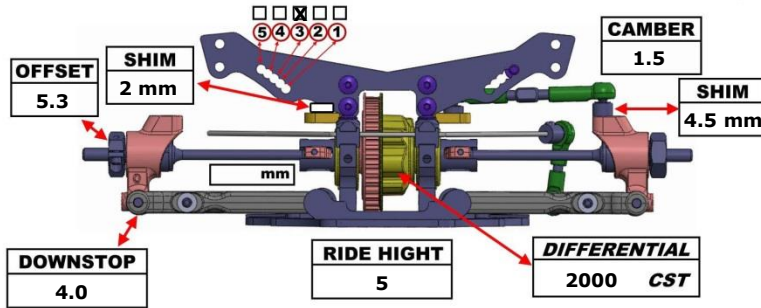

Track Info:  Indoor  Outdoor  CARPET  ASPHALT

Temp: Track 18° / Weather Sun

Track Type:  Technical /  Mixed /  Fast

Track Traction:  Low /  Medium /  High

BODY: LTCR WING: \_\_\_\_\_

MOTOR: 13.5 TM PowerTiming: No timing

ESC: Flow LRP BATTERY: 7200 R1 Wurks

TIRES: F LRP G32 / R LRP G32

DIAMETER: F / R

INSERS: F / R

ADDITIVE: F LRP C / R LRP C

TRACK COMMENTS:

Track treated with cola



	FRONT	REAR
OIL	350	350
SPRING	RSD Silver	RSD Silver
HOLES DIAMETER	1.1	1.1
PRELOAD		
FOAM INSERTS		
REBOUN	0 %	0 %
LENGTH		
O-RING ON SHAT		

SUSPENSION BLOCK (A)	SUSPENSION BLOCK (B)	CHASSIS	SUSPENSION BLOCK (C)	SUSPENSION BLOCK (D)
0	2.5	V2 Flex	2.5	2.5
ROLLING CENTER SHIM	ROLLING CENTER SHIM	TOP DESK	ROLLING CENTER SHIM	ROLLING CENTER SHIM
No	No	2 mm	No	No

