

COMMENTS:

Mounted Front spool axle
CSO-18053SH, ECS
44mm (Front) CSO-20195

Position 2° Place
Category Stock 13.5T

Date: May 18, 2014

Driver: Valter Cola

EVENT: Warm-Up AMSCI

Track/Tation: Track L.Collari – Cassino - Italy

FRONT

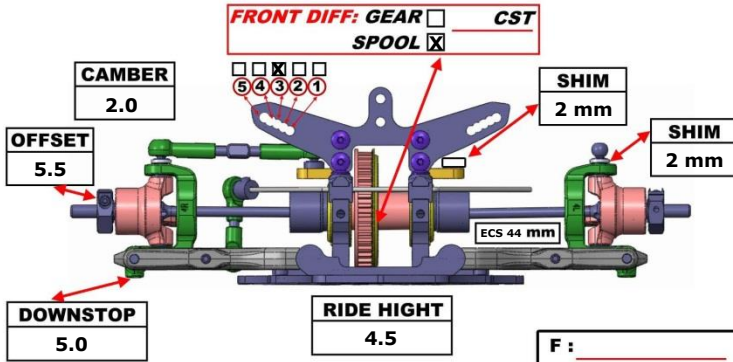

REAR

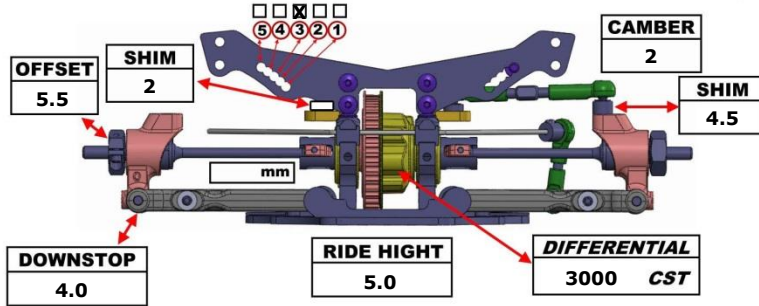

Track Info: Indoor Outdoor CARPET ASPHALT

Temp: Track _____ / Weather _____

Track Type: Technical / Mixed / Fast

Track Traction: Low / Medium / High

BODY : LTCR WING: _____

MOTOR : Team Powers 13.5 TIMING: No Timing

ESC : Flow LRP BATTERY: R1 Wurks 7200

TIRES : F Hot Race 36 / R Hot Race 36

DIAMETER: F / R

INSERTS : F / R

ADDITIVE : F Team Powers / R Team Powers

TRACK COMMENTS:

FRONT REAR

OIL	350	350
SPRING	RSD Blu Light	RSD Silver
HOLES DIAMETER	1.1	1.1
PRELOAD		
FOAM INSERTS	No	No
REBOUN	0 %	0 %
LENGTH		
O-RING ON SHAT		



SUSPENSION BLOCK (A)	SUSPENSION BLOCK (B)	CHASSIS	SUSPENSION BLOCK (C)	SUSPENSION BLOCK (D)
0	2.5		2.5	2.0
ROLLING CENTER SHIM	ROLLING CENTER SHIM	TOP DESK	ROLLING CENTER SHIM	ROLLING CENTER SHIM
No	No	2 mm	No	No

