

COMMENTS:

Motor hobbywing 10.5T
Variador flow timing 0
STOCK

Date: May 11, 2014

Driver: Xavi Vilanova Gonzalez

EVENT:

Track/Tation: CRC Rubi Cataluña - España

FRONT

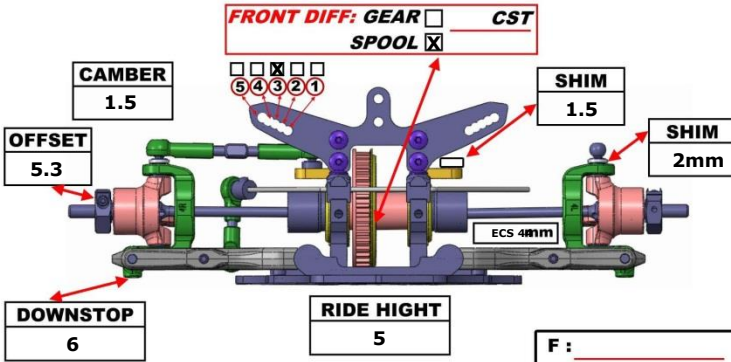

REAR

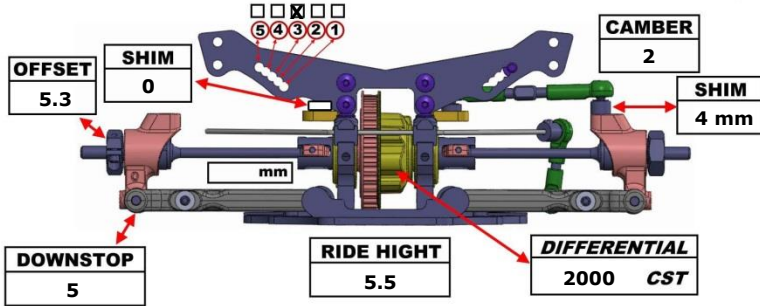

Track Info: Indoor Outdoor CARPET ASPHALT

Temp: Track _____ / Weather soleado

Track Type: Technical / Mixed / Fast

Track Traction: Low / Medium / High

BODY: GSF WING: blitz

MOTOR: 10.5T TIMING: Timing 0

ESC: FLOW BATTERY: LRP 7000

TIRES: F Ride 34 / R Ride 34

DIAMETER: F / R

INSERS: F / R

ADDITIVE: F Trinity / R Trinity

TRACK COMMENTS:

FRONT REAR

	FRONT	REAR
OIL	350	350
SPRING	CSO 2.6	CSO 2.6
HOLES DIAMETER	1.1/3	1.1/3
PRELOAD		
FOAM INSERTS	No	No
REBOUN	0 %	0 %
LENGTH		
O-RING ON SHAT		

SUSPENSION BLOCK (A)	SUSPENSION BLOCK (B)	CHASSIS	SUSPENSION BLOCK (C)	SUSPENSION BLOCK (D)
0	2.5	CSO V2	2.5	3
ROLLING CENTER SHIM	ROLLING CENTER SHIM	TOP DESK	ROLLING CENTER SHIM	ROLLING CENTER SHIM
No	No	2 mm standard	No	No

